

RETEKESS

CD BOOMBOX with AM/FM Radio

TR621 User Manual

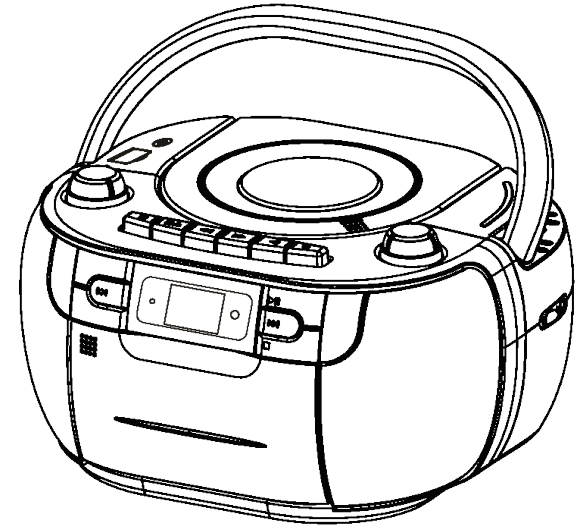
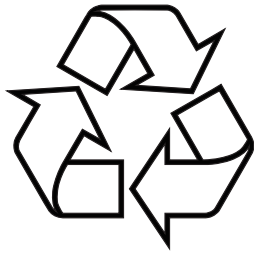

CE FC RoHS



Henan Eshow Electronic Commerce Co., Ltd.

Add: 7/F, Sanjiang Building, No.170 Nanyang Road, Huiji District,
Zhengzhou, Henan, China

Facebook: facebook.com/RetekessRadio

E-mail: support@retekess.com

Web: www.retekess.com



MADE IN CHINA

NOTE: PLEASE READ THE FOLLOWING INSTRUCTIONS CAREFULLY BEFORE OPERATING THIS EQUIPMENT.

1, Please follow the prescribed steps while using the CD player, or you may suffer from harmful radiation. This CD player is a CLASS 1 LASER (I class laser) products.

2, When the CD cover is opened or negligently closed, invisible laser light will be generated, the item need to avoid irradiation of the radiation beam.

3, Please do not touch CD mechanism at will, otherwise it will affect the playback performance.

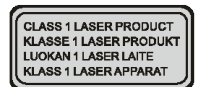

IMPORTANT SAFETY INSTRUCTION

1. Do not use this product near water and moisture, for example: near a bathtub, washbowl, kitchen sink or laundry tub; in a wet basement; or near a swimming pool.
2. Do not install near any heat sources such as radiators, heat registers, stoves, or other apparatus (including amplifiers) that produce heat.
3. Do not block any ventilation openings. Slots and openings in the cabinet and in the back or bottom are provided for ventilation, to ensure reliable operation of the product and to protect it from overheating. These openings must not be blocked or covered. The openings should never be blocked by placing the product on a bed, sofa, rug, or other similar surfaces. This product should never be placed near or over a radiator or heat source.
4. Object and liquid entry. Never push objects of any kind into this product through openings as they may touch dangerous voltage points or short-out parts that could result in fire or electric shock. Never spill or spray any type of liquid on the product.
5. Unplug this product from the wall outlet before cleaning. Do not use liquid cleaners or aerosol cleaners. Only use a dry cloth for cleaning.
6. Only use attachments/ accessories specified by the manufacturer.

POWER USAGE AND PRECAUTIONS

IMPORTANT

Before connecting AC power or installing batteries, make sure that the function switch is set to the off position. This machine can only connect or use the specified battery and AC household power.

TO OPERATE THE UNIT USING AC POWER

Plug one end of the AC power cord into the AC power jack and the other end into a 110V household power outlet.

- When the AC plug was inserted into the AC IN Jack, the battery power will be cut off automatically.
- When the switch is in the off position, the power supply in the machine is not completely cut off, and the power supply can only be cut off completely by unplugging the power plug.
- When unplugging the AC power cord, you should hold the plug part instead of only pull the power cord
- Never touch the AC power plug when your hands are wet. Otherwise it may cause fire or electric shock
- Protect the power cord from being walked on or pinched particularly at plugs, convenience receptacles, and the point where they exit from the apparatus.

BATTERY OPERATION

Install (or replace the batteries when it is drained) as below

1. Slide the Battery Door (on the bottom of unit) out then lift it off.
2. Insert six 1.5Vum1 type batteries (not included) according to the polarity diagram inside the battery compartment.
3. Replace the battery door.

BATTERY PRECAUTIONS

Follow these precautions when using a battery in this device:

1. Use only the size and type of battery specified.
2. Be sure to follow the correct polarity when installing the battery as indicated in the battery compartment .A reversed battery may cause damage to the device.
3. Do not mix different types of batteries together or old batteries with fresh ones.
4. If the device is not to be used for a long period of time ,remove the battery to prevent damage or injury from possible battery leakage.
5. Do not try to recharge the battery not intended to be recharged; it can overheat and rupture.
6. Do not dispose of batteries in fire. Battery may explodes or leak.
7. Clean the battery contacts and also those of the device prior to battery installation.
8. Unplug this apparatus during lightning storms or when unused for long periods of time.

LOCATION OF CONTROLS

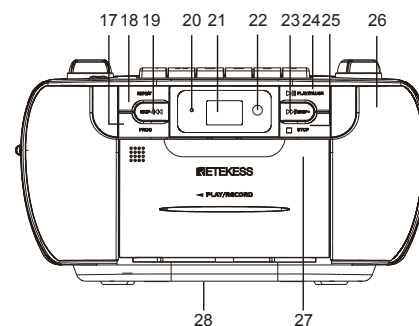
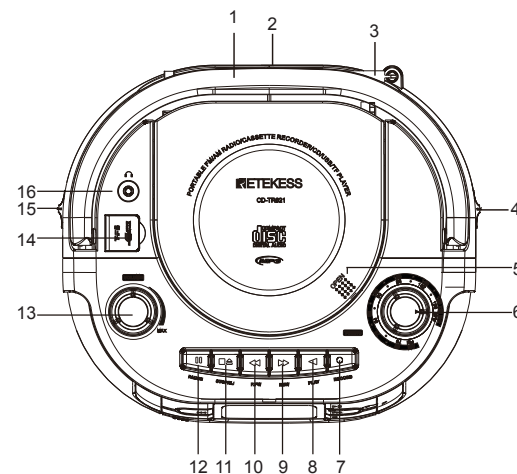

1. Carry Handle
2. AC~ Socket
3. FM Telescope Antenna
4. Bank Selection Button
5. CD Door OPEN/CLOSE Area
6. Station Selection Knob
7. Record Button
8. Play Button
9. Skip/Fast Backward Button
10. Skip/Fast Forward Button
11. Stop/Cassette Tape Door Open Button
12. Pause Button
13. Volume Control Knob
14. USB/TF Card Socket
15. Function Selector
16. Headphone Jack
17. Program Button
18. Repeat Button
19. Previous Song/Fast Backward Button
20. Power Indicator
21. LCD Display
22. Remote Control Receiver
23. Next Song/Fast Forward Button
24. Play/Pause Button
25. Stop Button
26. Built-in Mic
27. Cassette Tape Door
28. Battery Compartment

REMOTE CONTROL

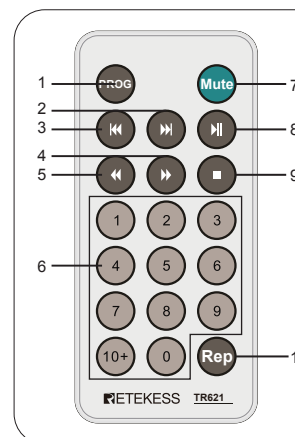

1. Program Button
2. Next Song Button
3. Previous Song Button
4. Skip/Fast Forward Button
5. Skip/Fast Backward Button
6. Number Keypad
7. Mute Button
8. Play/Pause Button
9. Stop Button
10. Repeat Button

LCD DISPLAY

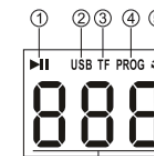

1. Play/Pause Mode
2. USB Play Mode
3. TF Card Play Mode
4. Program Play Mode
5. Single Song Repeat Mode
6. Song Name

OPERATION

REMOTE CONTROL

1. Program Button: When the CD / USB / TF card stops playing, press this key to enter the programming operation.
2. Next Song Button: In the state of playing CD / USB / TF card, press this key to select the next song to play.
3. Previous Song Button: In the state of playing CD / USB / TF card, press this key to select the previous song to play.
4. Skip/Fast Forward Button: In the state of playing CD / USB / TF card, press and hold this key to fast forward searching the specific section.
5. Skip/Fast Backward Button: In the state of playing CD / USB / TF card, press and hold this key to fast backward searching the specific section.
6. Number Keypad: When playing a CD / USB / TF card, you can use the numeric keys to select a specific song.
7. Mute Button: During playback, press this key to mute mode and press it again back to normal playback.
8. Play/Pause Button: During CD / USB / TF card playback, press this button to pause playback, and press this button again to resume playback.
9. Stop Button: In the state of playing CD / USB / TF card, press this button to stop playing.
10. Repeat Button: During CD / USB / TF card playback, press this key to repeat a single track or all tracks.

CD PLAYER OPERATION

1. Slide the Function Selector (15) to CD position
 2. Press the OPEN/CLOSE Area on the CD Door (5) to open it then place a CD disc on the center spindle, with the printed side face up
 3. Close the CD door by pressing the OPEN/CLOSE area (5). Wait a few seconds; "CD" letters will appear on the LCD Display
 4. Player will start playing the first track on the disc after closed the CD door.
 5. During playback:
 - Turn the VOLUME Control Knob (13) to adjust volume level as desire.
 - Press the Play/Pause Button (24) to pause; press it again to resume normal playback
 - Press the Skip/Fast Forward (9) and Skip/Fast Forward (10)Buttons repeatedly to skip the tracks.
 - Press and hold the Skip/Fast Forward (9) and Skip/Fast Forward (10) Buttons to fast searching the specific section.
 - Press the Repeat Button(18) once to single song repeat mode, "🔄" shows on display; Press the Repeat Button(18) twice to all song repeat mode, "🔄" shows on display; Press the Repeat Button(18) three time to cancel the repeat mode.
 - Press Stop Button (25) to stop playing.
 6. When the CD is stopped, press the Program Button (17) to set the CD programming. Press the button (17) once the song name on LCD display flashes, press the Previous Song Button (19) and Next Song Button (23) select the track you want to program. Press the Program Button(17) again to complete the operation, repeat the above steps to program multiple tracks, press the Play/Pause Button (24) to play the corresponding tracks in sequence, if you need to cancel the programming playback, just press the Stop Button (25).
- (Note: The above operations can also be done with the remote control)

USB/TF CARD OPERATION

- Insert the USB / TF card into the USB / TF Card Socket (14), slide the Function Selector (15) to position, then wait a few seconds, the tracks will appear on the LCD Display.
- NOTE: The files in USB/TF card must be in MP3 or WMA format. If USB and TF card are inserted at the same time, USB playback priority.

RADIO OPERATION

1. Slide the Function Selector (15) to RADIO position to turn on the radio

2. Press the BAND Selection Button (4) repeatedly to select AM or FM band as desire
3. Turn the Station Selection Knob (6) to select the desired station.
4. Turn the VOLUME Control Knob (13)to adjust volume level as desired.

NOTE: If the unit produces noise due to the influence of nearby appliances, (such as a TV, computer, or fluorescent light), you should move the unit to another place to listen to the radio.

Antennas:

AM:

This unit has a built-in internal magnetic antenna, which provides adequate reception in most areas. If reception is weak, turn the unit to improve reception.

FM:

The FM Telescopic Antenna is for FM reception only. If reception is weak, adjust the length and the angle of the antenna.

CASSETTE TAPE PLAYER OPERATION

1. Slide the Function Selector (15) to Cassette Tape position
2. Press the Stop/Cassette Tape Door Open Button (11) to open the Cassette Tape Door (27) and place a cassette tape in it correctly, then close the Cassette Tape Door (27).
3. Press Play Button (8) to play the track of the cassette tape.
4. Turn the VOLUME Control Knob (13) to adjust volume level as desire.
5. Press the Skip/Fast Forward (9) and Skip/Fast Forward (10) Buttons to fast searching the specific section.
6. Press Play/Pause Button (12) to pause, press again to resume normal playback.
7. Press Stop/Cassette Tape Door Open Button (11) to stop the tape playback.

RECORD OPERATION

1. Put the tape to be recorded into the tape compartment correctly, and close the door. Rewind the tape to the position where you want to start recording.
2. Record the sound of CD disc or USB / TF card, slide the Function Selector (15) to the position of CD or USB / TF card to play.
3. To record radio, slide the Function Selector (15) to the position of Radio and tune to the desired radio station.
4. Press the Record Button (7) to start recording, at this time the Play Button (8) will be pressed.
5. If you need the stop the recording, press Stop Button (11) will be OK.
6. To record an external audio source, slide the Function Selector (15) to the position of "tape" and press the Record Button (7) to record.

OTHER OPERATIONS

Power Off: slide the Function Selector (15) to the position of "tape".

Listen with Headset: Using stereo headphone, insert it into the Headphone Jack (16).

CARE AND MAINTENANCE

1. Do not expose compact discs to direct sunlight, high humidity, high temperatures or dust, etc. To prevent fire or shock hazard, disconnect your unit from the AC power source when cleaning. The finish on your unit may be cleaned with a dust cloth and cared for as other furniture. Use caution when cleaning and wiping the plastic parts.
2. Head Cleaning: After every 10 hours of tape playback, you should clean the magnetic head and pinch roller spindle. You should use cotton with a little cleaning fluid or alcohol for cleaning or use a dry or wet cleaning tapes.
3. After the recording is complete, use a screwdriver or other sharp tool to break the scratch-proof film on the tape to expose the scratch-proof hole.
4. Cover the tape scratch-proof hole with adhesive tape, you can use the tape to record again

GENERAL SPECIFICATIONS

Parameter	Model	110V PLAYER	220V PLAYER
Power Source		AC 110 V~, 60Hz	AC 220 V~, 50Hz
Output Power		2W+2W	2W+2W
Frequency Range:FM		76-1 08MHz	76-1 08MHz
Frequency Range:MW		530-1 600kHz	530-1 600kHz
Tape Speed:		4.76CM/S±3%	4.76CM/S±3%
CD playback frequency response		50Hz-18KHz	50Hz-18KHz
Tape playback frequency response		100Hz- 8KHz	100Hz- 8KHz
Maximum power consumption		12W	12W
Impedance of Speakers		77MM, 6ohm	77MM, 6ohm
Size		260*219*139mm	260*219*139mm
Weight		2kg (without battery)	2kg (without battery)

ACCESSORIES

Item Name	Quantity
CD BOOMBOX	1
AC Power Cord	1
Remote Control	1
Uer's Manual	1

RF ENERGY EXPOSURE AND PRODUCT SAFETY GUIDE

 ATTENTION!	<p>Before using this radio, read this guide which contains important operating instructions for safe usage and RF energy awareness and control for compliance with applicable standards and regulations.</p>
--	--

Local Government Regulations

When radios are used as a consequence of employment, the Local Government Regulations requires users to be fully aware of and able to control their exposure to meet occupational requirements. Exposure awareness can be facilitated by the use of a product label directing users to specific user awareness information. Your Reteless radio has a RF Exposure Product Label. Also, your Reteless user manual, or separate safety booklet includes information and operating instructions required to control your RF exposure and to satisfy compliance requirements.

Unauthorized modification and adjustment

Changes or modifications not expressly approved by the party responsible for compliance may void the user's authority granted by the local government radio management departments to operate this radio and should not be made. To comply with the corresponding requirements, transmitter adjustments should be made only by or under the supervision of a person certified as technically qualified to perform transmitter maintenance and repairs in the private land mobile and fixed services as certified by an organization representative of the user of those services. Replacement of any transmitter component (crystal, semiconductor, etc.) not authorized by the local government radio management departments equipment authorization for this radio could violate the rules.

FCC Requirements:

- This device complies with part 15 of the FCC Rules. Operation is subject to the following two conditions:
 - (1) This device may not cause harmful interference, and
 - (2) this device must accept any interference received, including interference that may cause undesired operation.

- This equipment has been tested and found to comply with the limits for a Class B digital device, pursuant to Part 15 of the FCC Rules. These limits are designed to provide reasonable protection against harmful interference in a residential installation. This equipment generates uses and can radiate radio frequency energy and, if not installed and used in accordance with the instructions, may cause harmful interference to radio communications. However, there is no guarantee that interference will not occur in a particular installation. If this equipment does cause harmful interference to radio or television reception, which can be determined by turning the equipment off and on, the user is encouraged to try to correct the interference by one or more of the following measures:
 - Reorient or relocate the receiving antenna.
 - Increase the separation between the equipment and receiver.
 - Connect the equipment into an outlet on a circuit different from that to which the receiver is connected.
 - Consult the dealer or an experienced radio/TV technician for help.

CE Requirements:

- (Simple EU declaration of conformity) Henan Eshow Electronic Commerce Co.,Ltd declares that the radio equipment type is in compliance with the essential requirements and other relevant provisions of RED Directive 2014/53/EU and the ROHS Directive 2011/65/EU and the WEEE Directive 2012/19/EU; the full text of the EU declaration of conformity is available at the following internet address: www.retekess.com.
- Disposal
The crossed-out wheeled-bin symbol on your product, literature, or packaging reminds you that in the European Union, all electrical and electronic products, batteries, and accumulators (rechargeable batteries) must be taken to designated collection locations at the end of their working life. Do not dispose of these products as unsorted municipal waste. Dispose of them according to the laws in your area.

IC Requirements:

- Licence-exempt radio apparatus
This device contains licence-exempt transmitter(s)/receiver(s) that comply with Innovation, Science and Economic Development Canada's licence-exempt RSS(s). Operation is subject to the following two conditions:
 - (1) This device may not cause interference.
 - (2) This device must accept any interference, including interference that may cause undesired operation of the device.

Le présent appareil est conforme aux CNR d'Industrie Canada applicables aux appareils radio exempts de licence. L'exploitation est autorisée aux deux conditions suivantes :

 - (1) l'appareil ne doit pas produire de brouillage;
 - (2) l'utilisateur de l'appareil doit accepter tout brouillage radioélectrique subi, même si le brouillage est susceptible d'en compromettre le fonctionnement.

RF Warning Statements

The device has been evaluated to meet general RF exposure requirement. The device can be used in portable exposure condition without restriction.

RF Exposure Information

- DO NOT operate the radio without a proper antenna attached, as this may damage the radio and may also cause you to exceed RF exposure limits. A proper antenna is the antenna supplied with this radio by the manufacturer or an antenna specifically authorized by the manufacturer for use with this radio, and the antenna gain shall not exceed the specified gain by the manufacturer declared.
- To avoid interference, turn off the radio in areas where signs are posted to do so.
- DO NOT operate the transmitter in areas that are sensitive to electromagnetic radiation such as hospitals, aircraft, and blasting sites.

Avoid Choking Hazard



Small Parts. Not for children under 3 years.

Protect your hearing:



- Use the lowest volume necessary to do your job.
 - Turn up the volume only if you are in noisy surroundings.
 - Turn down the volume before adding headset or earpiece.
 - Limit the amount of time you use headsets or earpieces at high volume.
 - When using the radio without a headset or earpiece, do not place the radio's speaker directly against your ear
 - Use careful with the earphone maybe possible excessive sound pressure from earphones and headphones can cause hearing loss
- Note: Exposure to loud noises from any source for extended periods of time may temporarily or permanently affect your hearing. The louder the radio's volume, the less time is required before your hearing could be affected. Hearing damage from loud noise is sometimes undetectable at first and can have a cumulative effect.

Approved Accessories



- This radio meets the RF exposure guidelines when used with the Reteless accessories supplied or designated for the product. Use of other accessories may not ensure compliance with the RF exposure guidelines and may violate regulations.
- For a list of Reteless-approved accessories for your radio model, visit the following website: <http://www.Reteless.com>

Cut along this line

Guarantee

Model Number: _____
 Serial Number: _____
 Purchasing Date: _____
 Dealer: _____ Telephone: _____
 User's Name: _____ Telephone: _____
 Country: _____ Address: _____
 Post Code: _____ Email: _____

Remarks:

- 1.This guarantee card should be kept by the user, no replacement if lost.
 - 2.Most new products carry a two-year manufacturer's warranty from the date of purchase.
 - 3.The user can get warranty and after-sales service as below:
 - Contact the seller where you buy.
 - Products Repaired by Our Local Repair Center
 - 4.For warranty service, you will need to provide a receipt proof of purchase from the actual seller for verification
- Exclusions from Warranty Coverage:
- 1.To any product damaged by accident.
 - 2.In the event of misuse or abuse of the product or as a result of unauthorized alterations or repairs.
 - 3.If the serial number has been altered, defaced, or removed.

EU Importer:
 Name: Germany Retevis Technology GmbH
 Address: Uetzenacker 29,38176 wendeburg